

DRUG - ↓

SEE BOTTOM

OK TO SEND TO AT&T O&E.

COMPANY CONFIDENTIAL

(SPEC 50204 NOT READY)

Teletype Corporation
R & D Organization

~~This Material Should Not
Be Distributed Outside of
Teletype Corporation~~

Specification 60,571S
Reissue of November 22, 1963

ENGINEERING SPECIFICATION FOR THE 195415
MODIFICATION KIT TO PROVIDE A THREE SPEED GEAR
SHIFT FOR A MODEL 28 KEYBOARD OR BASE

60-67-100

INTERNAL
CONTROL

TABLE OF CONTENTS

| <u>Section</u> | | <u>Total Pages In Section</u> |
|----------------|--|-----------------------------------|
| I | General Description and Engineering Requirements | 1 |
| II | Detailed Description and Theory of Operation | 2 |
| III | Adjustments, Special Requirements, and Lubrication | 2 |
| IV | Manufacturing Information | 1 |
| V | Installation and Servicing Instructions | 5* |

PAGE CHECK LIST

| <u>Section</u> | <u>Pages</u> | <u>Date</u> |
|----------------|--------------|-------------|
| I | I-1 | *11-18-63 |
| II | II-1 | *11-22-63 |
| | II-2 | *11-18-63 |
| III | III-1 | *11-18-63 |
| | III-2 | *11-18-63 |
| IV | IV-1 | *11-22-63 |
| V | V-1 | *11-18-63 |
| | V-2 | *11-18-63 |
| | V-3 | *11-18-63 |
| | V-4 | *11-18-63 |
| | V-5 | *11-18-63 |

*Plans for external control have been developed. BTL has sample
returned it to 5555 with blessings - so the next we can
get is a bill of material. The parts won't be made until
needed. It's quite a job to install so I think a new code
card will be initiated - of course wire used to cutting metal, etc. so
Let's go WYL!!!*

ENGINEERING SPECIFICATION FOR THE 195415
MODIFICATION KIT TO PROVIDE A THREE SPEED GEAR
SHIFT FOR A MODEL 28 KEYBOARD OR BASE

SECTION I

GENERAL DESCRIPTION AND ENGINEERING REQUIREMENTS

1. GENERAL DESCRIPTION

- *a. The 195415 Modification Kit is designed to provide a Model 28 KSR or RO with a three speed gear shift to be operated by a maintenance man. It is to be mounted on a keyboard or base in place of the intermediate gear assembly and is compatible with either a Mark II or Mark III Keyboard or Base. The modification kit is for field or factory installation. The gear shift is actuated by the manual operation of a lever mounted on the left side of the gear shift. This modification kit is not compatible with an LD mounted on the keyboard or base, the 164848 Modification Kit to provide parallel output contacts for Mark III Keyboards, or with the 163146 Modification Kit to provide universal contact on a printer. It is also incompatible with the wall mount printer. If this modification kit is to be installed on a keyboard which is equipped with either the 152916 or 154145 Local Reverse Line Feed Modification Kit, two of the local reverse line feed parts must be replaced. These replacement parts are not supplied with the 195415 Gear Shift Modification Kit but are available as Modification Kit 11,9896.

2. ENGINEERING REQUIREMENTS

- a. The 195415 Modification Kit provides a three speed gear shift designed to operate a Page Printer (LP) and Keyboard (IK) at 45.5, 50 and 74.2 baud, 7.42 unit code (60, 67, 100 wpm). The shaft speed of the driving motor is to be 3600 rpm. The gear shift is operated manually by the movement of a lever mounted on the keyboard or base. Speed selections may be made while the motor is running but it is necessary to open the cabinet to reach the shift lever.
- *b. The 195415 Modification Kit provides an eccentric follower pawl compatible with the 152338 Modification Kit to provide the Mark II Keyboard with a time delay mechanism or with the 154142 Modification Kit to provide the Mark III Keyboard with a time delay mechanism. When the 195415 Modification Kit is used, the pawl and eccentric supplied with the time delay mechanism are to be discarded. The replacement eccentric follower pawl is slotted to allow insertion into the gear shift assembly if the time delay mechanism is to be used.

*SECTION II

DETAILED DESCRIPTION AND THEORY OF OPERATION

1. DETAILED DESCRIPTION

- *a. The 195415 Modification Kit consists of a 195170 Speed Shift Gear Bracket Assembly similar to the 145410 Speed Shift Gear Bracket Assembly except the 75 wpm gear set is replaced by a 67 wpm gear set. The 195415 Modification Kit provides an eccentric follower pawl to drive a time delay mechanism. The time delay mechanism is not provided. A shift lever is mounted at the left edge of the gear bracket assembly (behind the printer) to operate the speed selection mechanism.

2. THEORY OF OPERATION

- * a. The operation of the 195170 Speed Shift Gear Bracket Assembly is similar to that of the 145410 Speed Shift Gear Bracket Assembly. The mechanism is comprised of three constantly meshed gear sets, one for each speed of 60, 67 and 100 wpm. The pinions are pinned to a common drive shaft geared to the motor. The driven gears may be selectively keyed to the driven shaft and thus to the load through an idler gear. The key, which is fitted into a keyway in the driven shaft, may be moved left or right as illustrated in Figure 1. The right end of the key (as viewed from the front of the keyboard) is spring biased radially outward from the shaft center. Action in selecting different operating speeds is as follows, starting with the key engaged in the center gear as shown in Figure 1. As the key is moved left or right, the key is cammed radially inward toward the center of the shaft against its spring by the action of the cam surface against the inner shoulder of the gear. This action disengages the key from the center gear. The key remains in the disengaged position until it is moved past the shoulder of the adjacent gear. As this adjacent gear rotates on the keyed driven shaft, the slot on the inner bearing surface of the gear will align itself with the right end of the key, which has been positioned approximately at the center of the gear. When this occurs, the key will snap radially outward into engagement with the gear, under the action of the spring.
- b. The key is coupled to the inner flanged sleeve by means of an extension into a hole in the sleeve. The inner flanged sleeve and key rotate with the shaft.
- c. The inner flanged sleeve rotates within the non-rotating outer bearing sleeve, which is coupled to the operating linkage. The outer bearing sleeve acts against the flanges of the inner flanged sleeve to move the inner flanged sleeve and key axially along the shaft during operation of the shift lever.

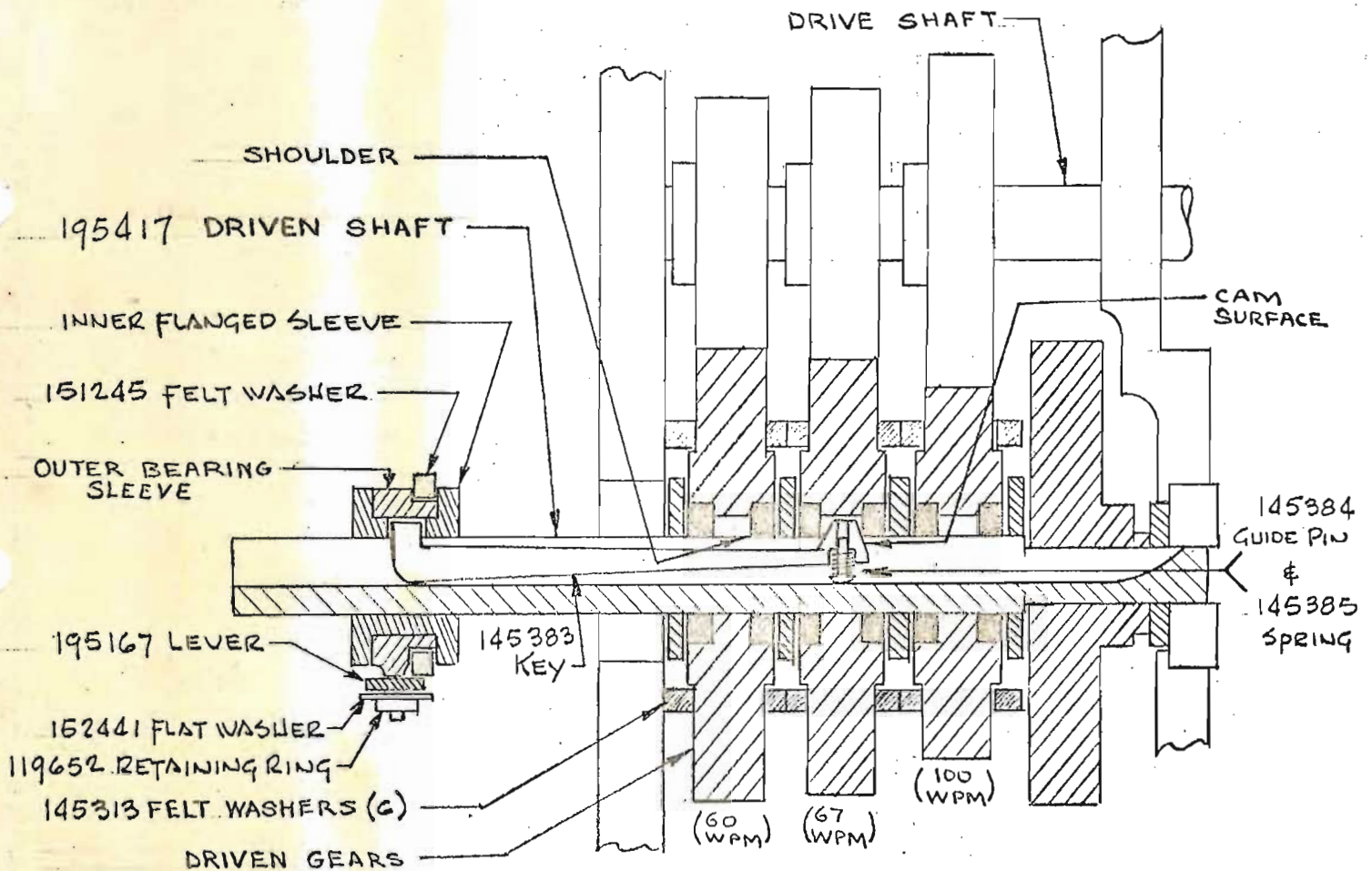

OPERATION OF SPEED SHIFT GEAR BRACKET
ASSEMBLY AND ASSOCIATED PARTS.

NOT TO SCALE

FIGURE 1

SECTION III

ADJUSTMENTS, SPECIAL REQUIREMENTS, AND LUBRICATION

1. ADJUSTMENTS

a. Gear shift assembly adjustment to driven gear, motor pinion and time delay mechanism. (Refer to Figure 2)

*(1) Requirement - There shall be .004 to .008 inch backlash between the motor pinion and its driven gear and between the speed shift gear bracket assembly idler and its driven gear on the Printer (LP).

(2) Requirement - The 195420 Pawl should be positioned relative to the associated parts of the time delay mechanism so that it rides freely without binding on the 195418 Gear and Eccentric.

*(3) Requirement - There shall be some clearance between the motor end bell and the 145366 Gear Shift Input Gear.

** (4) To adjust - Loosen the three screws which mount the speed shift gear bracket assembly and loosen the two lock nuts which lock the adjusting bushings at the rear of the assembly. Position the assembly and adjust the height at the rear by means of the adjusting bushing nearest to the motor. The other bushing should be backed out for clearance. After correct adjustment has been obtained, lock the adjusting bushing nut. Turn the other bushing with the fingers until it touches the base and tighten the lock nut. Tighten all mounting screws and recheck requirements.

*b. Shift Lever Bracket Adjustment (Refer to Figure 3)

*(1) Requirement - The 195167 Shift Lever shall be positioned within the detent notches in the 195163 Bracket.

*(2) To adjust - Loosen the three 151631 Screws which mount the 195163 Bracket and reposition the bracket. Tighten the mounting screws.

*c. Terminal Block Mounting Bracket Adjustment (Refer to Figures 3 and 4)

*(1) Requirement - There shall be a .062 minimum clearance between the 195169 Terminal Block Mounting Bracket and each of the three gears below the bracket.

*(2) Requirement - The formed tab on the 149881 Cover shall rest securely on the gear bracket so as to prevent rattling.

*(3) To adjust - Loosen the two 151630 Screws which mount the 195169 Bracket to the 195163 Shift Bracket. Raise or lower the free end of the 195169 Bracket and tighten the mounting screws.

2. SPECIAL REQUIREMENTS

*a. If this gear shift modification kit is to be installed on a keyboard which is equipped with either the 152916 or 154115 Local Reverse Line Feed Modification Kit, two parts in the local reverse line feed mechanism must be replaced as follows:

** (1) Replace the bracket, Part No. 153246 (Mark II Keyboard) or Part No. 154132 (Mark III Keyboard) with Part No. 149885.

** (2) Replace the transfer bail, Part No. 153249 (Mark II or Mark III Keyboard) with Part No. 149884.

**NOTE: The above replacement parts are not supplied with the 195415 Gear Shift Modification Kit but must be ordered separately under Modification Kit 149896.

*b. For adjustments relating to the time delay mechanism, local reverse line feed mechanism, and eccentric follower pawl, see applicable specifications for the 152338, 154115, 152916 or 154112 Modification Kits.

*c. Key Spring Tension

*(1) It shall require 25 to 40 ounces applied above the spring to depress the key to its lowermost position in the slot.

*(2) To measure, it is necessary to disconnect the operating linkage by removing the retaining ring and moving the operating end of the key out from under the gears. Use care to avoid loss of pin and spring.

3. LUBRICATION

a. Use KS7470 Oil or KS7471 Grease as listed below. Lubricate during installation and each time keyboard or base is lubricated thereafter.

(1) Grease

(a) Nine gears - light coat around periphery of gears.

(2) Oil

*(a) Both pivot points of shift lever - 1 or 2 drops of oil.

(b) All felt washers - saturate.

(c) Oilite bearing in casting - 1 or 2 drops.

(d) Flanged sleeve and bearing - light coat.

(e) Key and spring - light coat.

(f) Eccentric follower pawl - 1 or 2 drops at eccentric bearing surface.

SECTION IV

MANUFACTURING INFORMATION

1. MANUFACTURING INFORMATION

*a. General

- (1) The 195415 Modification Kit shall be manufactured in accordance with released prints, bills of material, and engineering specifications.
- (2) All screws and nuts shall be tight and free from burrs.
- (3) The finish shall be free from cracks, scratches, blisters, and corrosion.
- (4) All moving parts shall be free from binds.
- (5) There must be some clearance between the 195418 Gear and the 159341 Bearing.
- (6) There must be some end play in the three driven gears on the driven shaft.
- (7) Gears must mesh by at least $7/8$ of gear thickness.

SECTION V

INSTALLATION AND SERVICING INSTRUCTIONS

1. INSTALLATION

a. General

- (1) The 195415 Modification Kit is packed in an individual cardboard carton.
- (2) Unpack kit by cutting carton at sealed edges, being careful not to damage unit.

b. Mounting of Kit

- *(1) Remove Printer (LP) and Motor Unit (LMU) and remove the keyboard or base from cabinet.
- *(2) Remove from the keyboard and discard the following items:
 - ** (a) Intermediate gear assembly and associated mounting facilities. Save one of the two 151712 Pivot Buttons.
 - ** (b) Connector and motor terminal block mounting bracket. Retain all connector and terminal block mounting hardware.
- *(3) Insert two 198680 Clamping Screws through the 198679 Bracket. (See Figure 2.) Fasten the bracket to the top of the keyboard or base. Place the bracket mounting screws through the slots at the rear of the keyboard or base, vacated by the intermediate gear assembly. Position bracket at forward edge of slots (toward printer) and tighten.
- *(4) Place gear bracket assembly over clamping screws. Assemble remaining 198680 Clamping Screw and associated hardware through the remaining slot vacated by the intermediate gear assembly.
- *(5) Position 151245 Felt Washer on 145386 Sleeve Assembly. See Figure 1.
- *(6) Insert 145383 Key into keyway of 195417 Shaft with 145385 Spring and 145384 Pin in place. Hold spring depressed. See Figure 1.
- *(7) With the left end of the 145383 Key extending beyond the left end of the 195417 Shaft, position the extension of the left end of the key, in the hole on the inner bearing surface of the sleeve assembly and slide the sleeve assembly onto the 195417 Shaft. Care must be taken that the spring and pin at the right end of the key remain in alignment as the key slides into the bearing in the 195158 Bracket. The 145386 Sleeve Assembly should be assembled on the 195417 Shaft with the 151245 Felt Washer nearest the 195158 Bracket Casting.

- *(8) Assemble the 195167 Lever to the 195163 Bracket. (See Figure 2.) Assemble the 195163 Bracket to the gear shift casting. Fasten the lower end of the 195167 Lever to the 145386 Collar.
- *(9) Mount the connector to the 195168 Bracket using retained hardware and following reverse of removal procedure.
- *(10) Fasten the 195168 Bracket and 195169 Terminal Block Bracket to the bracket mounted to the gear shift casting. Place the 195169 Bracket between the 195168 Bracket and the gear shift bracket. Use two each 151630 Screw and 2191 Lockwasher. See Figure 3.
- *(11) Fasten the motor terminal block to the 195169 Bracket using retained hardware.
- *(12) Fasten the 145365 Motor Pinion to the motor with a 159287 Retainer and two 161301 Posts.
- *(13) If a time delay mechanism is to be used, insert the 195420 Pawl into the gear bracket assembly. The open end of the pawl fits on the eccentric hub of the 195418 Gear as shown in Figure 4.
- ***(14) Adjust and lubricate per Section III of this specification.
- ***(15) Mount 149881 Cover on top of terminal block as shown in Figure 4. Replace the original screws in the 151335 Posts with two 151631 Screws. Add two 7002 Flat Washers.

2. SERVICING

- *a. To service this mechanism it is not necessary to remove the keyboard from the cabinet. Remove printer, motor unit, and 149881 Cover. Follow Section V-1, Paragraph b. for re-assembly.

NOTE: Upon completion of installation of this modification kit it should be shifted through its three speed selections while the motor is running to assure interference free operation of the shift linkage. If 7.42 unit code, 45.5, 50, and 75 baud transmission lines are available, it is suggested that the printer associated with this gear shift could be connected to these signal lines to check proper speed of operation. If a time delay mechanism is used with this kit it should be checked to assure proper operation.

- * Indicates Change
- ** Indicates Addition

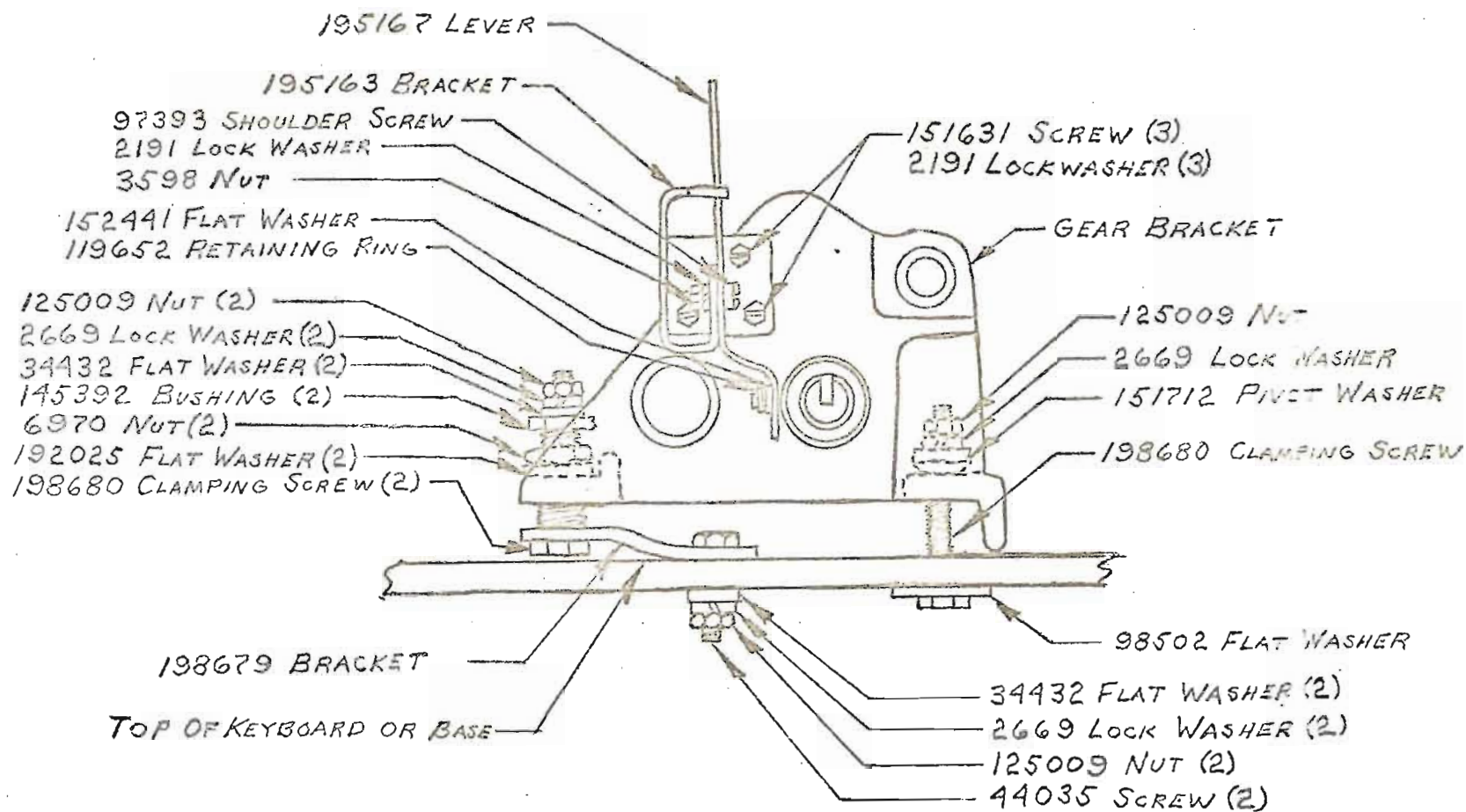

FIGURE 2

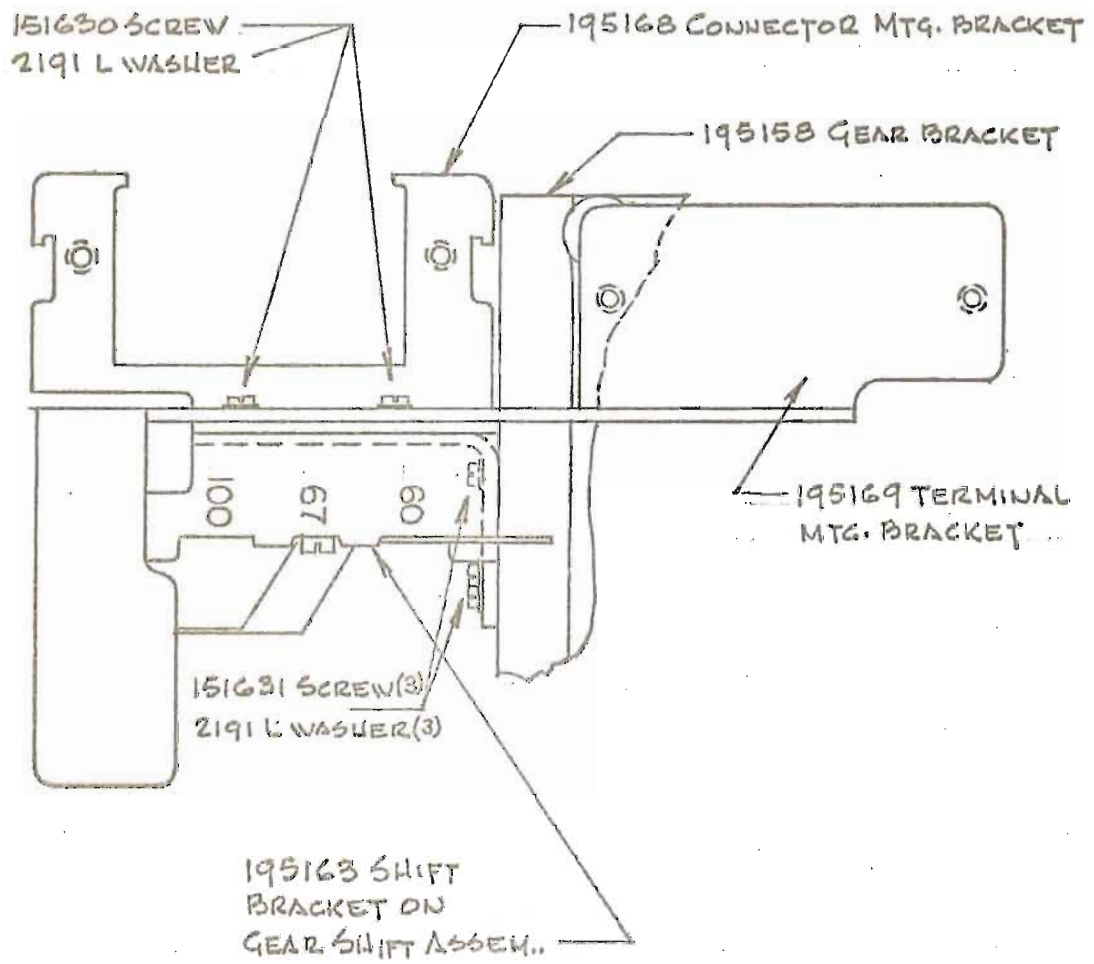

FIGURE 3

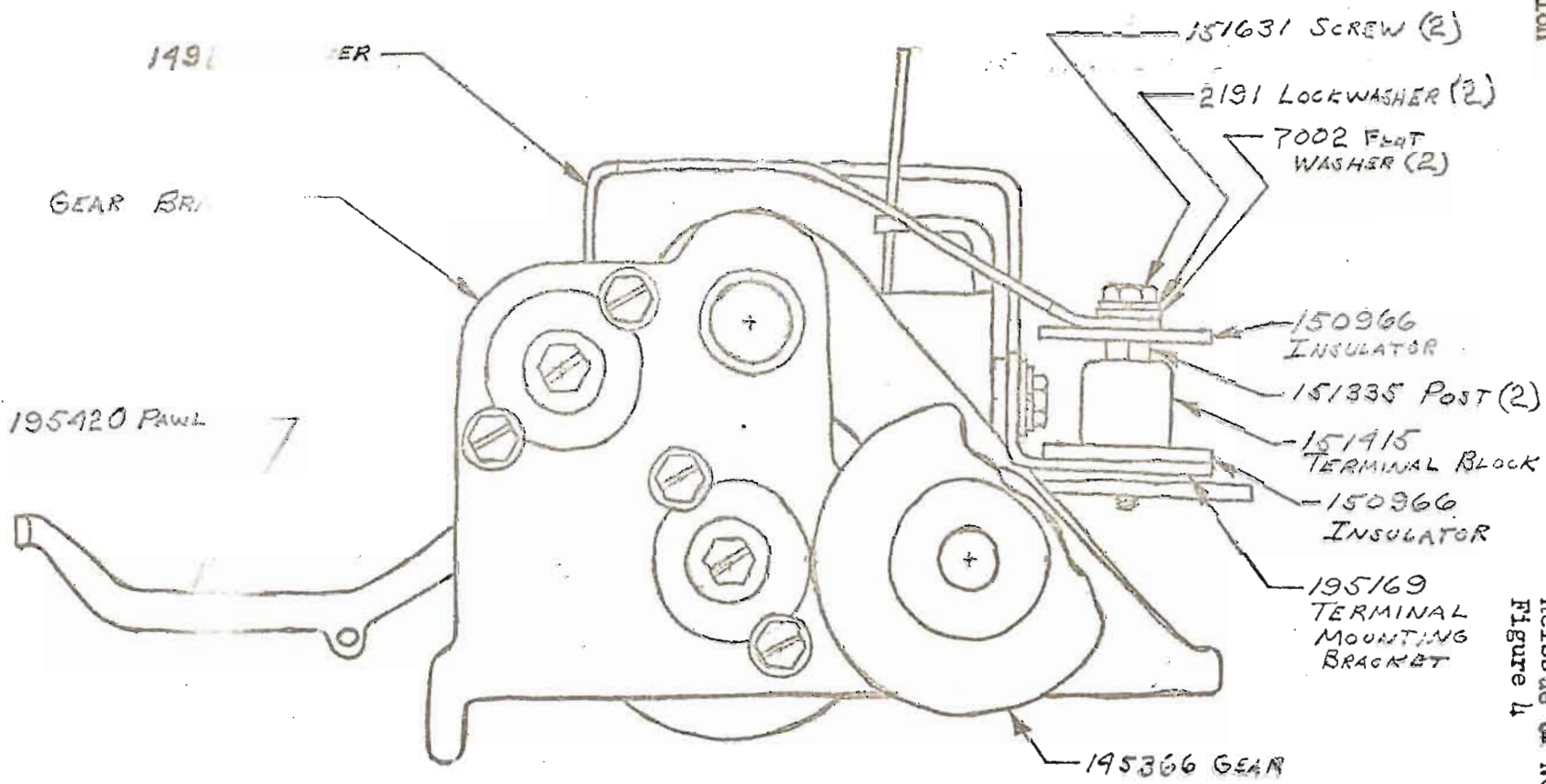

FIGURE 4