

## **BOOTH AND SHELF CLEANING**

### **1. GENERAL**

**1.01** This section describes the procedures for cleaning booths and shelves of aluminum, stainless steel, enameled metal, plastic glass, fiberglass, and wood.

**1.02** The booth should be cleaned from top down.

If the operator cannot reach the top of booth, a stepladder should be used. Remove all foreign stickers by soaking with a sponge soaked with warm water. The use of a razor blade for scraping purposes is permitted on glass surfaces only. Sharp instruments will score metal surfaces and their use should be avoided. Clean the telephone housing and handset, using a cloth **DAMPENED, NOT SATURATED**, with an approved mild detergent solution.

**1.04** Care should be used to avoid any spray or excessive solution from getting into coin slots and perforations in the receiver and transmitter caps.

### **2. TOOLS AND MATERIAL**

**2.01** The following tools and materials are suggested for booth and shelf cleaning:

- Hand Sprayer\*
- Nylon Brush\*
- Utility Wiping Cloths
- Short Stepladder
- Sponge, Synthetic
- Whisk Broom (or equivalent—purchased locally)
- Rubber Gloves
- Safety Glasses
- Putty Knife

● C7-, or KS-19432, List 1 Multipurpose Cleaners (or equivalent)

● KS-8446 Solvent

● KS-7860 Petroleum Spirits

● Automobile Paste Wax

● Bell System Metal Polish (or equivalent)

● Emery Cloth (fine grit)

\* May be purchased locally or through GNR Corp. Palmer, Mass.

### **3. PREPARATION OF TELEPHONE BOOTH PRIOR TO CLEANING**

**3.01** Sweep out and dispose of all rubbish found in the booth and in the immediate vicinity.

**3.02** Use rubber gloves in all cleaning operations to avoid any possible skin complications due to cuts or allergies.



*Use safety glasses when spraying cleaning solutions overhead or when removing dome assembly.*

### **4. CLEANING BOOTH AND SHELF MATERIAL**

#### **Wood and Headboard**

**4.01** Clean the external surfaces which are *not* badly scratched or marred with a 10 to 1 solution of C7 multipurpose cleaner or an approved mild detergent and warm water. After drying, file or sand sharp edges or splinters on exposed surfaces and polish with an approved polish.

**4.02** When condition of external surface is such that cleaning would not be sufficient, the surface should be replaced or refinished.

**Plastic, Fiberglass, Porcelain and Enamel**

**4.03** Clean exposed surfaces with a 10 to 1 solution of C7 multipurpose cleaner or an approved mild detergent. Rinse with water and dry with clean cloth. Heavy deposits of greasy or wax base substances may be removed with KS-7860 petroleum spirits.

**Warning:** *KS-7860 petroleum spirits is highly flammable. Use safety precautions while it is being used.*

**Note:** Do not use abrasive cleaners or materials on transparent plastic as dulling and scratching may result.

**4.04** Polish with good quality automobile paste wax and soft cloth.

**Unpainted Aluminum And Stainless Steel**

**4.05** Remove all burrs and scratches from aluminum and stainless steel surfaces using fine grit emery cloth.

**4.06** KS-8446 solvent may be used to remove paint spots. KS-7860 petroleum spirits may be used to remove wax base substances.

**4.07** Remove stubborn stains and deposits from unpainted aluminum and stainless steel surfaces by applying Bell System liquid metal polish (or equivalent) with a wiping cloth.

**4.08** Cover surfaces from which anodized finish has been removed with a coat of hard paste wax.

**5. CLEANING OPTIONAL EQUIPMENT**

**THINK** Turn power off before working on lighting equipment or electrical wiring.

**5.01** Clean exterior of dome lamps and shields with a mild solution of C7 multipurpose cleaner or equivalent.

**5.02** See Fig. 1 for removal of dome assembly. Clean fluorescent lamp and interior of light

shield with mild soap and warm water. Dry thoroughly.

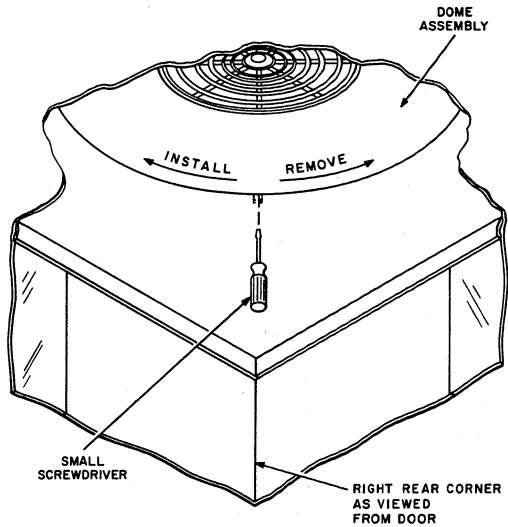

- NOTES:**
1. FOR REMOVAL, INSERT SMALL SCREWDRIVER THROUGH SLOT IN CEILING, DEPRESS DETENT SPRING, AND TURN DOME ASSEMBLY COUNTERCLOCKWISE.
  2. FOR INSTALLATION, PLACE DOME ASSEMBLY IN CEILING AND TURN IT CLOCKWISE UNTIL DETENT SPRING ENGAGES AND LOCKS DOME.

**Fig. 1—Method For Removing Dome Assembly**



**Do not use petroleum spirits or paint solvents.**

**5.03** Ensure that the insect screen, if provided, in the front sign enclosure, is free of foreign material.

**6. INSPECTION OF BOOTH**

**6.01** Report any and all obvious damage, such as missing or badly worn directories, broken glass, inoperative lights, doors, etc, to supervisor. Remove all stickers, gum, markers, and posters not placed by the Telephone Company. If decals

placed by the Telephone Company are damaged, remove decals. Replace all burned out lamps and starters.

**6.02** Place a cleaning date seal, furnished by the Telephone Company, in the upper right hand

interior of the booth (not on glass) and write in the cleaning date. If the seal is already placed, remove previous date and write in latest cleaning date. Replace the seal as required.